

## Introduction

The function of a Pressure Relief Valve is to protect against over-pressure. For safety reasons, excessive over-pressure in any part of the refrigeration system must be avoided.

## Applications

A typical application for a Henry Technologies pressure relief valve (PRV) is to protect a liquid receiver from being over-pressurised. In the event of a fire, any liquid refrigerant inside the receiver will evaporate resulting in an increase in pressure. The PRV will safely control this increase in pressure by venting the vapour from the receiver. Another application is to protect equipment from compressor over-pressure.

Henry Technologies pressure relief valves are designed to discharge vapour and should not be used to vent liquid refrigerant. The valves are “back-pressure dependent” and are therefore required to discharge to atmosphere. The brass and stainless steel series valves are suitable for use with HCFC and HFC refrigerant gases. The stainless steel series valves are also suitable for ammonia. Once a PRV has discharged, replacement is recommended, as the set pressure can no longer be guaranteed. Refer to Installation Section for further information. In line with the Institute of Refrigeration Guidelines (UK), Henry Technologies recommend that a PRV should be replaced at least every 5 years. These intervals may have to be reduced if other regulations apply. It is recommended to have a relief valve pressure setting at least 25% higher than the maximum system operating pressure. The PRV set pressure should not be higher than the design pressure (MWP) of the vessel.



## How it works

A conventional PRV is designed to open at a predetermined pressure - the set pressure. A spring exerts a sealing force on a valve seat via a piston seal assembly. At a pressure equal to the set pressure, the piston will start to lift resulting in a small amount of flow through the valve. From this point, the force acting on the piston increases significantly and overcomes the spring force. Due to the larger piston diameter this imbalance of forces causes the valve to “pop” fully open. By design, the difference in pressure from the valve set point to the fully open condition is no more than 10%. System pressure is controlled/reduced by venting the refrigerant vapour through the valve. The valve then re-closes at a pressure where the spring force overcomes the piston force. Under normal system operating conditions, the pressure at the valve inlet is below the set pressure. Only under abnormal operating conditions should the PRV be open.

## Main features

- **Brass construction set and sealed** at the factory; all N.P.T.F. connections are American Standard dry-seal tapered pipe threads.
- **Valves are stamped** with catalogue number, size, pressure setting, capacity and ASME-UV National Board symbol; CRN number and flow arrow.
- **Consistent operation** at marked pressure setting.
- **These relief valves** are designed with HENRY'S “Centre Loading Pivot” concept allowing the piston to reseat squarely to the body seat, thus reducing the possibilities of leakage.
- **Suitable** for refrigerants R22, R134a, R404a, R410a, R500, R502 and other industrial fluids non-corrosive to brass, monel, steel, Neoprene and Teflon.
- **Factory set and sealed. Tamper Proof.**
- **Temperature rating:** -20°F (-28°C) to +160°F (+71°C).
- **Orders must specify** catalogue number, pressure setting, and type of refrigerant or fluid with which the valve is to be used; UV/NB certified setting range varies with design, see ratings sheet; contact Heldon for non-certified setting range info.
- **Non-standard pressure settings** available on request.
- **Test Certificates** available on request.

## Selection of Relief Valves

Henry Pressure Relief Valves conform to the "American Standard Safety Code for Mechanical Refrigeration (ANSI/ASHRAE 15)." This code and ASME states a relief valve setting is not to exceed the design working pressure of the vessel on which the relief valve is installed. The discharge capacity required is based on the size of the vessel and the refrigerant used. The discharge capacity of relief valves varies with the pressure setting. The capacities of Henry Relief Valves at various pressure settings are available by contacting Heldon Products Australia.

Whenever conditions permit it is highly advisable to have the relief valve pressure setting (which must not exceed the design working pressure of the vessel) at least 25% higher than the normal maximum operating pressure for the refrigerant used.

Standard Pressure Settings					
Brass		Steel		High Pressure	
psig	barg	psig	barg	psig	barg
150	10.34	150	10.34	500	34.47
235	16.20	250	17.24	550	37.92
300	20.68	300	20.68	600	41.37
350	24.13			650	44.82
400	27.58			675	46.54
450	31.03				

**Important:** Orders must specify pressure setting.

**Certification:** Available if requested on purchase order, (-C) suffix, i.e. 5600-300-C

**Relief Valve Capacity Ratings:** (lbs per min. / kg per min.) - Henry Relief valves are constructed and marked in accordance with the requirements of the ASME (Boiler and Pressure Vessel Code Section VIII, Division 1). These valves are also approved by many local refrigeration and air conditioning codes in the USA and Canada for relief of excess pressure.

In addition, these valves are stamped with the ASME UV symbol and NB to indicate National Board Certification as to capacities.

In Australia, these valves are compatible with the Australian Standard, **AS 1271-2003**.

In Paragraph 3.5.4 of this document it states that "a certificate that a valve complies with this standard may be issued on the basis of tests previously conducted, and certification may be given to rate the discharge capacity of valves on the basis of tests conducted outside the Commonwealth of Australia. Certification for approval for such valves shall be supported by documentation of the tests, and sufficient information to prove that the test results being submitted apply to the valves under consideration."

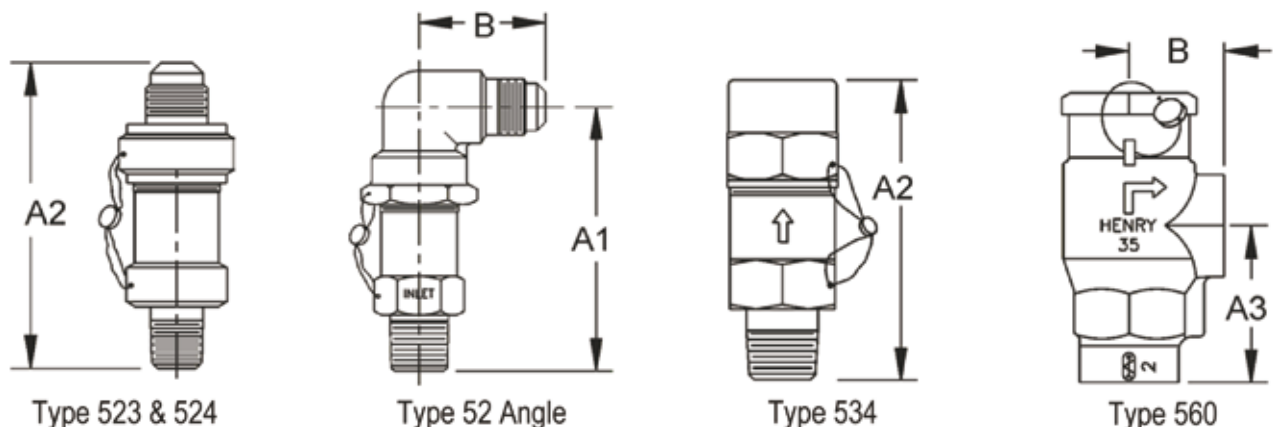

## Straight-Through Relief Valves

Catalogue No.	Size Connections		Length in "A2" mm	Orifice Diameter mm	Weight g
	Inlet	Outlet			
5230	1/4" M.P.T.	3/8" SAE	80.26	6.35	172.37
5231	3/8" M.P.T.	3/8" SAE	80.26	6.35	176.90
5232	1/2" M.P.T.	5/8" SAE	101.60	11.10	385.55
5232B	1/2" M.P.T.	1/2" F.P.T.	102.11	11.10	439.99
5240N1/2	1/2" M.P.T.	3/4" F.P.T.	95.00	7.93	430.91
5242N3/4	3/4" M.P.T.	3/4" F.P.T.	95.00	7.93	467.20
* 5340N1/2	1/2" M.P.T.	3/4" F.P.T.	93.98	7.93	430.91
* 5342N3/4	3/4" M.P.T.	3/4" F.P.T.	93.98	7.93	467.20
5244-3/4	3/4" M.P.T.	1" F.P.T.	105.66	12.70	662.25
5244-1	1" M.P.T.	1" F.P.T.	105.66	12.70	662.25
* 5344-3/4	3/4" M.P.T.	1" F.P.T.	106.43	12.70	662.25
* 5344-1	1" M.P.T.	1" F.P.T.	106.43	12.70	662.25
5246N1	1" M.P.T.	1-1/4" F.P.T.	160.02	13.49	1133.98
5246N1-1/4	1-1/4" M.P.T.	1-1/4" F.P.T.	160.02	13.49	1179.34
* 5345N	1" M.P.T.	1-1/4" F.P.T.	160.02	13.49	1133.98
* 5346N1-1/4	1-1/4" M.P.T.	1-1/4" F.P.T.	160.02	13.49	1179.34
5233A	3/8" M.P.T.	7/8" SAE	115.82	6.35	476.27
5234A	3/8" M.P.T.	3/4" F.P.T.	106.68	6.35	476.27
5235A	1/2" M.P.T.	3/4" F.P.T.	111.76	6.35	508.02

\* Suitable for Ammonia R717

## Angle Relief Valves

Catalogue No.	Size Connections		Dimensions			Orifice Diameter (mm)	Weight (g)
	Inlet	Outlet	A1 (mm)	A3 (mm)	B (mm)		
526E	3/8" M.P.T.	3/8" SAE	75.18	-	35.81	6.35	181.44
527E	1/2" M.P.T.	5/8" SAE	96.77	-	43.69	11.10	385.55
* 5600	1/2" F.P.T.	3/4" F.P.T.	-	68.33	41.40	12.70	1632.93
* 5601	1/2" F.P.T.	1" F.P.T.	-	68.33	41.40	12.70	1560.36
* 5602	3/4" F.P.T.	1" F.P.T.	-	68.33	41.40	12.70	1542.21
* 5603	1" F.P.T.	1-1/4" F.P.T.	-	73.15	50.80	12.70	2154.56
* 5604	1-1/4" F.P.T.	1-1/2" F.P.T.	-	104.90	58.67	17.86	2948.35

\* Suitable for Ammonia R717

## Features

- **Bodies:** 5600 Series, Ductile Iron; 5300 Series, Stainless Steel; 5200 Series, Brass.
- **Seat inserts,** seat discs and main guides, piston stainless steel on 5600 series.
- **Seat material:** Teflon® or Neoprene.
- **Connections:** (NPTF) pipe threaded.
- **Other component** metal parts are steel.
- **Set and sealed** at the factory and furnished with nameplates stamped with catalogue no. size, pressure setting, capacity and ASMEUV National Board symbol.
- **Protective lacquer** finish on 5600 series.
- **Suitable for ammonia,** HFC's and CFC's, refrigerants and other industrial fluids non-corrosive to steel and Teflon as indicated.
- **Each valve** has unique serialization for tagging requirements.

PRV capacity rating (lbs of air per min. / kg of air per min.)						
Catalogue No.	Pressure Settings					
	150psi / 10.34barg	235psi / 16.20barg	300psi / 20.68barg	350psi / 24.13barg	400psi / 27.58barg	450psi / 31.03barg
5230	5lbs / 2.27 kg per min	7.6 / 3.45	9.6 / 4.36	11.2 / 5.08	12.7 / 5.76	14.3 / 6.49
5231	5lbs / 2.27 kg per min	7.6 / 3.45	9.6 / 4.36	11.2 / 5.08	12.7 / 5.76	14.3 / 6.49
526E	5lbs / 2.27 kg per min	7.6 / 3.45	9.6 / 4.36	11.2 / 5.08	12.7 / 5.76	14.3 / 6.49
5232	12.6lbs / 5.72 kg per min	19.1 / 8.66	24.2 / 10.98	28 / 12.7	31.9 / 14.5	35.7 / 16.19
5232B	12.6lbs / 5.72 kg per min	19.1 / 8.66	24.2 / 10.98	28 / 12.7	31.9 / 14.5	35.7 / 16.19
527E	12.6lbs / 5.72 kg per min	19.1 / 8.66	24.2 / 10.98	28 / 12.7	31.9 / 14.5	35.7 / 16.19
5240N1/2	13.1lbs / 5.94 kg per min	19.9 / 9.03	25.1 / 11.39	29.2 / 13.25	33.2 / 15.06	37.2 / 16.87
5242N3/4	13.1lbs / 5.94 kg per min	19.9 / 9.03	25.1 / 11.39	29.2 / 13.25	33.2 / 15.06	37.2 / 16.87
* 5340N1/2	13.1lbs / 5.94 kg per min	19.9 / 9.03	25.1 / 11.39	29.2 / 13.25	33.2 / 15.06	37.2 / 16.87
* 5342N3/4	13.1lbs / 5.94 kg per min	19.9 / 9.03	25.1 / 11.39	29.2 / 13.25	33.2 / 15.06	37.2 / 16.87
5244-3/4	33.2lbs / 15.06 kg per min	50.5 / 22.91	63.8 / 28.94	73.9 / 33.52	84.1 / 38.15	94.3 / 42.77
5244-1	33.2lbs / 15.06 kg per min	50.5 / 22.91	63.8 / 28.94	73.9 / 33.52	84.1 / 38.15	94.3 / 42.77
* 5344-3/4	33.2lbs / 15.06 kg per min	50.5 / 22.91	63.8 / 28.94	73.9 / 33.52	84.1 / 38.15	94.3 / 42.77
* 5344-1	33.2lbs / 15.06 kg per min	50.5 / 22.91	63.8 / 28.94	73.9 / 33.52	84.1 / 38.15	94.3 / 42.77
5246N1	44.6lbs / 20.23 kg per min	67.8 / 30.75	85.2 / 38.65	99.1 / 44.95	112.8 / 51.17	126.4 / 57.33
5246N1-1/4	44.6lbs / 20.23 kg per min	67.8 / 30.75	85.2 / 38.65	99.1 / 44.95	112.8 / 51.17	126.4 / 57.33
* 5345N	44.6lbs / 20.23 kg per min	67.8 / 30.75	85.2 / 38.65	99.1 / 44.95	112.8 / 51.17	126.4 / 57.33
* 5346N1-1/4	44.6lbs / 20.23 kg per min	67.8 / 30.75	85.2 / 38.65	99.1 / 44.95	112.8 / 51.17	126.4 / 57.33

\* Suitable for Ammonia R717

PRV capacity rating (lbs of air per min. / kg of air per min.)			
Catalogue No.	Pressure Settings		
	150psi / 10.34barg	250psi / 17.24barg	300psi / 20.68barg
* 5600	30.9lbs / 14.02 kg per min	45.1 / 20.46	59.4 / 26.94
* 5601	35.8lbs / 16.24 kg per min	52.2 / 23.68	68.7 / 31.16
* 5602	35.8lbs / 16.24 kg per min	52.2 / 23.68	68.7 / 31.16
* 5603	37.5lbs / 17.01 kg per min	54.7 / 24.81	71.9 / 32.61
* 5604	72lbs / 32.66 kg per min	105.1 / 47.67	138.1 / 62.64

\* Suitable for Ammonia R717

PRV capacity rating (lbs of air per min. / kg of air per min.)						
Catalogue No.	Pressure Settings					
	450psi / 31.03barg	500psi / 34.47barg	550psi / 37.92barg	600psi / 41.37barg	650psi / 44.82barg	675psi / 46.54barg
5233A	N/A	31.2lbs / 14.15 kg per min	34.2 / 15.51	37.2 / 16.87	40.3 / 18.28	41.8 / 18.96
5234A	N/A	31.2lbs / 14.15 kg per min	34.2 / 15.51	37.2 / 16.87	40.3 / 18.28	41.8 / 18.96
5235A	N/A	31.2lbs / 14.15 kg per min	34.2 / 15.51	37.2 / 16.87	40.3 / 18.28	41.8 / 18.96

## Selection Guidelines

For safety reasons, relief valve selection should only be carried out by suitably qualified engineers. It is important to select/size a relief valve taking into account all possible sources of over-pressure such as external heat, internal heat, compressor operation and liquid expansion. System control methodology, type of equipment used, etc. dictates the number of over-pressure sources that need to be taken into account for PRV selection.

Henry Technologies pressure relief valves are designed to discharge refrigerant vapour and are therefore not recommended for protection against liquid over pressure.

As a pressure relief valve is a safety device, it is essential that a proper selection is made.

**AS/NZS 1677.2 – 1998, Amendment 2 – 2000** is the relevant Australian Standard employed for pressure relief valve selection purposes.

Paragraph 3.7.4.1 of these standard, states the following.

The minimum required discharge capacity of the pressure relief devices for each pressure vessel related to air shall be determined by the following equation:

$$C = f \times D \times L$$

Where

**C** = minimum required discharge capacity of the relief device in kilograms of air per second.

**D** = outside diameter of the vessel, in metres.

**L** = length of vessel, in metres.

**f** = factor dependent on the refrigerant as follows:

Refrigerant	Value of <i>f</i>
When used on the low pressure side of a limited charge cascade system:	
R170, R744, R1150	0.082
R13, R13B1, R503	0.163
R14	0.203
When used in other applications:	
R717	0.041
R11, R40, R113, R123, R142B	0.082
R152A, R290, R600, R600A, R611	0.082
R764	0.082
R-401A, R-401B	0.115
R-402A, R-404A	0.180
R-402B	0.156
R12, R22, R114, R134A, R-407C	0.131
R-410A	0.197
R-C318, R500, R1270	0.163
R115, R502	0.203

An example selection is included here using this formula from the above reference.

## Example

A liquid receiver is to be protected from over-pressure due to fire.

Receiver dimensions = 2.2m long (L) x 0.254m outside diameter (D).

Refrigerant = R404A

Pressure setting = 20.68 barg.

Employing the formula:  $C = f \times D \times L$

$$C = 0.180 \times 0.254\text{m} \times 2.2\text{m}$$

$$C = 0.101 \text{ kg of air per second.}$$

This figure needs to be multiplied by 60 seconds per minute to arrive at the final value required.

$$C = 0.101 \text{ kg/sec} \times 60 \text{ sec/minute}$$

$$C = \mathbf{6.04 \text{ kg/minute.}}$$

Therefore, for this example suitable models are **5232**, **5232B** or **527E**. Each of these models is rated at **10.98 kg / minute**. The final choice depends on the preferred inlet and outlet connection sizes.

It is important not to grossly over-size a PRV as the performance can be affected. Contact Heldon Products Australia for further guidance.

## References:-

ANSI/ASHRAE 15 – 2004.

AS 1271 – 2003.

AS/NZS 1677.2 – 1998, Amendment 2 -2000.

## Installation – Main issues

1. Connect the relief valve at a location above the liquid refrigerant level, in the vapour space. Stop valves should not be located between the vessel and the relief valve except the three-way type.
2. Do not discharge the relief valve prior to installation or when pressure testing the system.
3. Pressure relief valves should be mounted vertically.
4. Relief valves should be changed out after discharge. Most systems are subject to accumulations of debris. Particles of metal and dirt are generally blown onto relief valve seats during discharge. This inhibits the relief valve from re-sealing at the original set pressure. A valve can also relieve at a lower pressure than the stamped valve setting due to the force of the re-closing action.
5. The pipe-work must not impose loads on the relief valve. Loads can occur due to misalignment, thermal expansion, discharge gas thrust, etc.

## Cross Reference Tables

### REFRIGERANT PRESSURE RELIEF VALVES

Barstock Relief Valves	Certified		Port Diam (inch)	Rated Slope (SCFM / psia)		Superior Valve (Sherwood)	Certified		Rated Slope	
	Range (psig)	Henry Valve		Range (psig)	/ psia		Range (psig)	/ psia	Range (psig)	/ psia

#### Angle Type

3/8" MPT in x 3/8" SAE out	150 - 450	526E	0.25	0.372	3214	150 - 500	0.39	A15512*	150 - 450	0.44
1/2" MPT in x 5/8" SAE out	150 - 450	527E	0.437	0.932	3220	150 - 500	0.77	A15514	150 - 450	0.96

#### Straight-Through type (MPT X SAE)

1/4" MPT in x 3/8" SAE out	150 - 450	5230	0.25	0.372	3012	150 - 500	0.39	A15501	150 - 450	0.21
3/8" MPT in x 3/8" SAE out	150 - 450	5231	0.25	0.372	3014	150 - 500	0.39	15502*	150 - 450	0.44
1/2" MPT in x 5/8" SAE out	150 - 450	5232	0.437	0.932	3020	150 - 500	0.77	A15504	150 - 450	0.96
1/2" MPT in x 1/2" FPT out	150 - 450	5232B	0.437	0.932	3030*	150 - 475	1.77			

#### Straight-Through type (MPT X FPT)

1/2" MPT x 3/4" FPT	150 - 450	5240N-1/2	0.315	0.971	3031*	150 - 475	1.77			
3/4" MPT x 3/4" FPT	150 - 450	5242N-3/4	0.315	0.971	3045*	150 - 475	1.77			
1" MPT x 1" FPT	150 - 450	5244-1	0.5	2.46	3060*	150 - 450	4.22	A17840	150 - 450	2.69
1-1/4" MPT x 1-1/4" FPT	150 - 450	5246N-1-1/4	0.531	3.3	3075*	150 - 450	4.22	A17834*	150 - 450	4.4

#### Straight-Through R717

1/2" FPT X 3/4" FPT	150 - 450	5340N-1/2	0.315	0.971						
3/4" FPT X 3/4" FPT	150 - 450	5342N-3/4	0.315	0.971						
1" FPT X 1" FPT	150 - 450	5344-1	0.5	2.46						

#### High Pressure Relief Valves

1/2" MPT x 1" FPT	450 - 600	6500	0.225	0.462						
3/4" FPT x 1" FPT	450 - 600	6501	0.225	0.462						

\* Check application's capacity requirements

### REFRIGERANT PRESSURE RELIEF VALVES

Angle Type Cast Body Relief Valves	Certified		Port Diam (inch)	Rated Slope (SCFM / psia)		Certified Range (psig)	Rated Slope (SCFM / psia)		Certified Range (psig)	Rated Slope (SCFM / psia)	
	Range (psig)	Henry Valve		Range (psig)	/ psia		Range (psig)	/ psia		Range (psig)	/ psia
1/2" FPT x 3/4" FPT	150 - 450	5600	0.5	2.29	H5600A	150 - 400	2.32	803	75 - 400	1.98	SRH1 150 - 400 2.58
1/2" FPT x 1" FPT	150 - 450	5601	0.5	2.65	H5601	150 - 350	2.65	813	75 - 400	1.99	SRH2 150 - 400 2.58
3/4" FPT x 1" FPT	150 - 450	5602	0.5	2.65	H5602	150 - 350	2.65	804	75 - 400	3.04	SRH3 150 - 400 2.58
1" FPT x 1-1-1/4" FPT	150 - 450	5603	0.5	2.773	H5613*	100 - 400	3.92	805-T	75 - 400	4.09	SRH4 150 - 350 4.44
1-1/4" FPT x 1-1/2" FPT	150 - 450	5604	0.703	5.33	H5604	150 - 400	5.33	-	-	-	SRH5 150 - 350 5.36

\* Check application's capacity requirements